

Kawasaki

90ZV-2

ENGINE POWER **202kW**(271hp) OPERATING WEIGHT **24ton** BUCKET CAPACITY **3.4-4.5m³**

W H E E L L O A D E R



Performance that new

Wheel loaders that deliver premium power...



Backed by more than 45 years of innovative experience...

Durability and reliability you can count on...

er quits...



As the oldest on-going manufacturer of rubber tire wheel loaders in the world, Kawasaki specializes in the design and manufacture of articulated wheel loaders.

You get a machine with a 45-year heritage of successful innovations.

The power and productivity that a Kawasaki wheel loader brings to the job is a result of that experience.

Kawasaki loaders are designed with durability to provide years of reliable service.

Backed by a dealer network of heavy equipment experts and dedicated support staff in the Kawasaki parts and service organization, your investment in a Kawasaki loader is an excellent choice that will pay dividends for years to come.

POWER AND **PERFORMANCE** **PROVIDE UNMATCHED** **PRODUCTIVITY**

A yellow Kawasaki wheel loader is shown from a high-angle perspective, positioned on a concrete ramp that slopes downwards to the right. The loader's bucket is lowered and facing towards the bottom left of the frame.

COMPUTER CONTROLLED ENGINE

The Engine Control Module (ECM) allows the engine performance to be modified to fit the application requirements. It also provides a wide range of operating data and fault codes to assist in diagnostic and troubleshooting. Cummins provides diagnostic tools to allow technicians to quickly recover engine information for fast, accurate analysis.

Euro Stage IIIA and EPA Tier III emission standards are met by using proven technologies that keep the overall design simple and less costly to maintain.



Use Kawasaki recommended fuel to prevent engine from damage. Consult your local Kawasaki dealer about Kawasaki recommended fuel.

POWER/FUEL EFFICIENT MODE SELECTION 01

The engine mode switch allows the operator to select either the power mode for maximum power in extreme applications or the fuel efficient mode, for most applications, which provides better fuel economy.

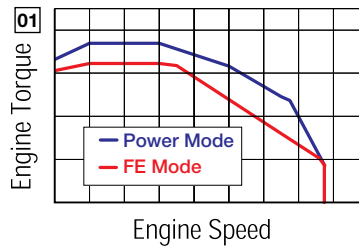

IDLE MANAGEMENT SYSTEM

The idle management system allows for lower idle speed when idling for extended periods to conserve fuel. It also increases idle speed and reduces fan speed when the engine is cold to reduce warm up time, for better productivity.

ADVANCED HYDRAULIC COOLING FAN CONTROL FEATURES 02

The hydraulically driven cooling fan's speed is controlled by the cooling system temperatures which reduces fan noise and improves fuel efficiency.

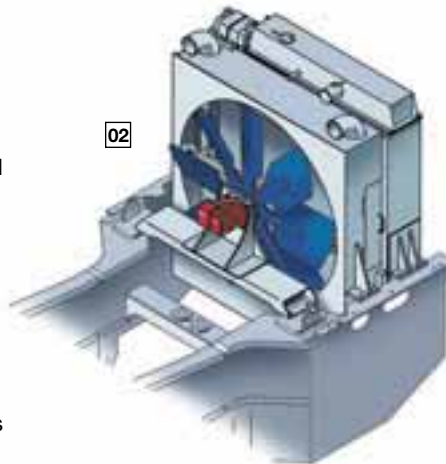

OUTBOARD WET DISC BRAKE 03

Sealed wet disc brakes provide high capacity braking and protection from contamination. The dual brake system separates the front and rear axles for added safety.

TPD 04

Standard Torque Proportioning Differentials (TPD) improve traction in slippery conditions.

LSD (OPT) 05

For applications with extreme traction requirements, the Limited Slip Differential (LSD) provides additional traction capability.

Z-LINK AND CENTER PIN ARTICULATION

As a pioneer of Z-linkage, Kawasaki loaders provide outstanding breakout force from a simple, reliable linkage. Kawasaki center pin design is rugged and durable, providing thousands of hours of trouble free operation.



ELS (Efficient Loading System) 06

Increases rimpull power and slows bucket movement when digging while demanding less fuel.

Increases productivity and fuel efficiency.

Switch on instrument control panel allows operator to activate from cab.



06

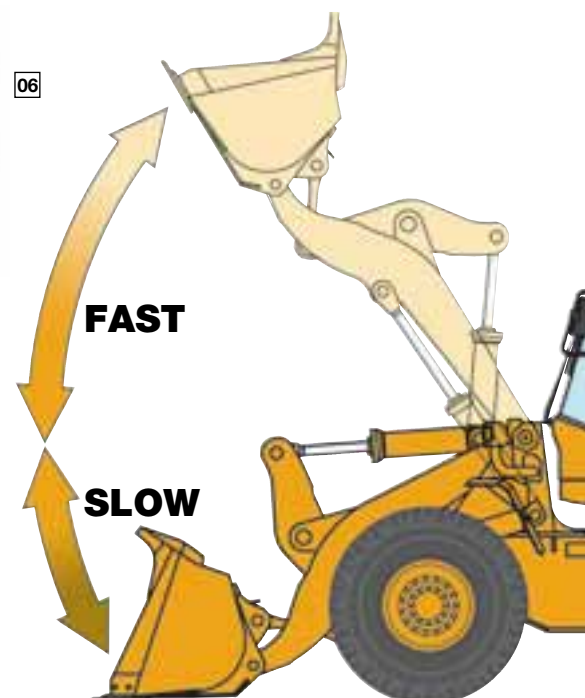

LOAD SENSING HYDRAULIC SYSTEM FOR STEERING LINE

An energy efficient design of the hydraulic system provides for steering flow to supplement the main circuit once steering demand is met. This allows for full utilization of the pump capacity for efficient operation in all conditions.

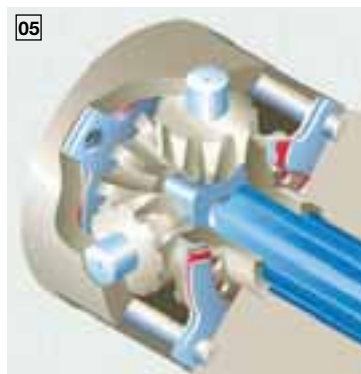

DURABLE AND DEPENDABLE

LIFT ARMS/BUCKETS 01

With the strongest lift arms and linkage in the industry, Kawasaki loaders perform well in a wide variety of applications.

High breakout force and excellent bucket rollback mean bigger loads and better load retention.

Buckets are designed for easy loading and are equipped with bolt-on cutting edges for easy changing.

The bucket leveler and boom kickout are standard.



SEALED BUCKET HINGE PINS 02

The special seal in the bucket hinge pin provides excellent sealing and grease retention which extends pin life.

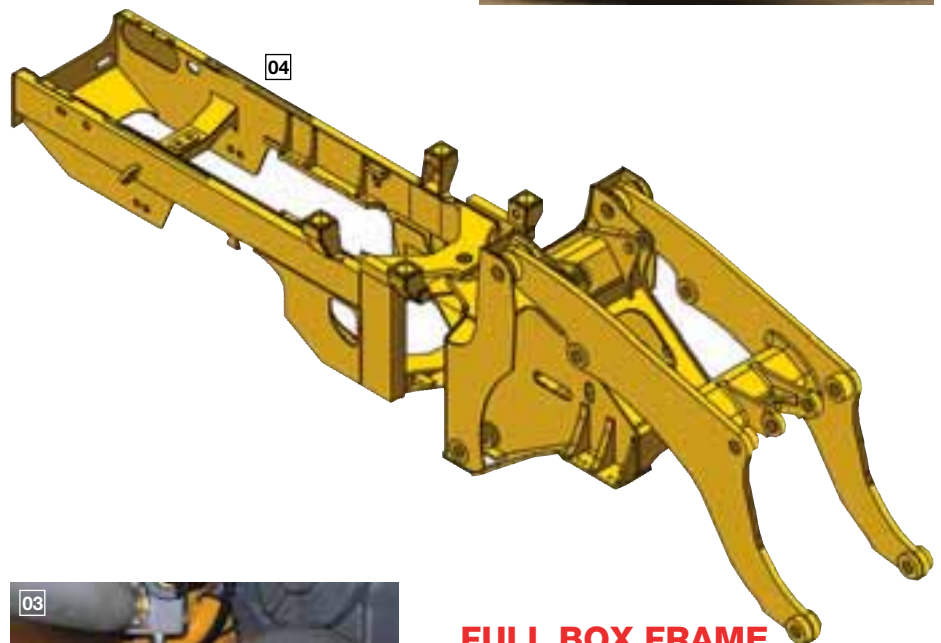

INCREASED GREASING INTERVALS FOR UNIVERSAL JOINTS 03

Sealed universal joints only require greasing every 12000 hours. This reduces maintenance costs significantly and provides greater durability.



FULL BOX FRAME CHASSIS 04

Full box section frame is the strongest in the industry and resists twisting loads better than plate frames.

RIDE CONTROL FEATURE (OPT) 05

Ride control offers a smooth ride to improve load retention and increase travel speeds.

BUFFER RINGS IN HYDRAULIC CYLINDERS

The hydraulic cylinders utilize a buffer ring to improve sealing capability to reduce leakage.

KAWASAKI MADE HYDRAULIC VALVES

As a leading manufacturer of precision hydraulic components, Kawasaki offers high quality control valves for precise operation.

Pilot assisted controls offer fingertip operation.

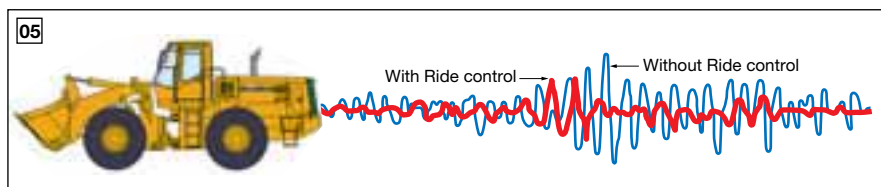

EASY ACCESS SIMPLIFIES SERVICING



EASY ACCESS SIMPLIFIES SERVICING

Maintenance is enhanced with the engine access panels that can be opened wide for better access.

Filters are conveniently located for easy change and the grease fittings are grouped to reduce maintenance time and insure proper lubrication.

HIGH QUALITY FINISH PAINT FOR SHEET METAL PARTS ⁰⁹

Kawasaki's sophisticated painting process utilizes ED (Electro-deposition) primer, a baked Melamine Alkyd finish coat as well as a fluoroc super protection coat for a durable and attractive finish.

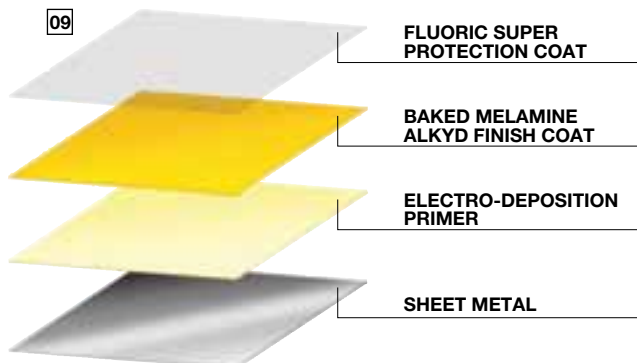

HALOGEN HEAD LAMPS ⁰⁶

Front and rear working lights are bright, halogen lamps for improved safety and visibility.

LED REAR LAMPS (OPT) ⁰⁷

Long life, LED lamps are available as an option for the rear tail lights.

These lights are very bright and durable.



DT CONNECTORS ⁰⁸

Sealed Deutsch DT electrical connectors are used throughout the system to reduce corrosion and provide a positive connection.



C THE COMFORT ZONE



CAB

Excellent visibility in all directions is enhanced with both inside and outside mirrors.

The front windshield is flat glass mounted in rubber gaskets that make windshield replacement fast and easy.

Viscous mounting of the cab reduces vibration and noise.

ROPS AND FOPS CAPABILITY 01

The operator's cab is fully certified to meet all ROPS (Rollover Protective Structure) and FOPS (Falling Object Protective Structure) regulations.



MULTI ADJUSTABLE FUNCTION OPERATOR'S SEAT 03

The fully adjustable suspension seat offers excellent comfort to reduce operator fatigue and increase productivity.

The optional air suspension seat provides higher capacity and overall comfort and reliability.

FULLY AUTOMATIC HEATER AND AIR CONDITIONER 02

The thermostatically controlled air conditioner/heater provides automatic adjustment to keep the operator comfortable in any environment.

The high capacity vents provide adequate airflow for efficient defrosting and an even temperature distribution.

By pressurizing the cab, the climate control system keeps dust out of the cab.

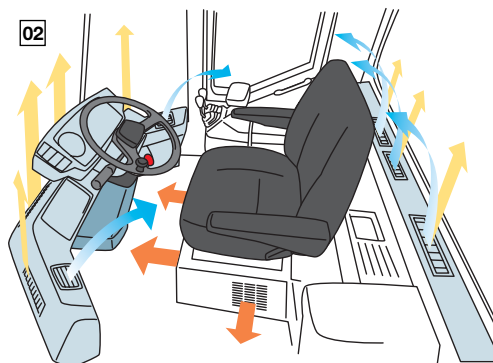



TILT AND TELESCOPIC STEERING

The tilt and telescopic steering column adjusts to fit a variety of operator needs and offers greater comfort and efficiency.

ADJUSTABLE DECLUTCH PRESET SWITCH ⁰⁶

The adjustable declutch system allows the operator to select the location of the left brake pedal where the declutch engages. This allows the operator to adjust for varying operating conditions easily.



IMPROVED KICKOUT FEATURE ⁰⁶

Dual boom kickout can be set by the operator from inside the cab.

A high kickout can be set for loading trucks or hoppers while a low kickout can be set to return the boom to the proper height for digging.

SHIFT HOLD SWITCH (OPT)

The shift hold switch allows the operator to hold the transmission in the current range with a convenient button located on the hydraulic control lever when the transmission is in the automatic mode.

K-LEVER (OPT)

K-LEVER joystick steering reduces operator fatigue and increases productivity.

Transmission speed selection is done with buttons on the K-Lever and direction changes are handled with the convenient trigger switch.

SINGLE SHIFT CHANGE LEVER

Single, twist grip transmission shift lever is conveniently mounted on the steering column.

MODM ⁰⁴

The MODM, Machine Operation Diagnostic Module, offers information to make the operation, maintenance and troubleshooting more efficient. With this information operators, maintenance and technical personnel can quickly determine key operating data.



RADIO (OPT) AND UTILITY BOXES

Operators appreciate the convenience of the radio, glove box, cup holder and climate controlled storage box.

ADDITIONAL DIRECTIONAL SWITCH (OPT) ⁰⁵

The directional switch located near the hydraulic control levers allows the operator to easily make directional shifts without removing his left hand from the steering wheel.



DOWNSHIFT BUTTON ⁰⁵

The downshift button located on the boom control lever provides for quick, convenient downshifting from 2nd gear to 1st gear.

90ZV-2 OPERATING SPECIFICATIONS

Engine

Make & model	CUMMINS "QSM11" diesel engine
Type	4-cycle, water-cooled, direct injection, with turbocharged and air cooled intercooler
Rated power	Gross 216 kW(284 hp)/2,100 rpm Net 202 kW(271 hp)/2,100 rpm
Maximum torque	Gross 1,478 N·m(150.8 kgf·m)/1,400 rpm
Number of cylinders (bore X stroke)	6 125 mm X 147 mm
Total displacement	10.83lit
Cooling type	Hydraulic drive pusher type fan Pressurized radiator
Fuel injection pump	Cummins high pressure injection
Governor	All-speed electrical type
Air cleaner	Dry type(Double element)
Generator	AC 24V 1.8 kW(75 ampere)
Starter motor	DC 24V 7.2 kW(9.6 hp)
Batteries	DC 12V 108 Ah X 2

Transmission & Torque converter

Transmission make & type	Kawasaki, Full power shift		
Torque converter make & type	Kawasaki 3-element, one-stage, one-phase		
Traveling speed		Forward	Reverse
	1st	6.9 km/h	7.6 km/h
	2nd	12.0 km/h	13.1 km/h
	3rd	21.4 km/h	23.3 km/h
	4th	33.5 km/h	35.1 km/h
Note	With 26.5(L3)		

Axles & Final Drives

Type	4-wheel drive
Axle make & type	Kawasaki Full floating type
Differential gear	Spiral bevel gear, torque proportioning, single stage reduction
Final reduction gear	Outboard mounted, Internal planetary gear
Rear axle oscillation angle	± 12 °
Tire(standard)	26.5(L3) tubeless

Weight change

Option item	Operating weight(kg)	Tipping load(kg)			Overall width(mm) (outside tire)	Overall height(mm)	Overall length(mm)	
		Straight	at 37 °	Full turn				
Tire	23.5R25(L3)	-560	-420	-365	-360	-85	-60	+50
	26.5R25(L3)	± 0	± 0	± 0	± 0	± 0	± 0	± 0
	26.5R25(L4)	+400	+300	+260	+255	+15	+30	-25
	26.5R25(L5)	+740	+555	+485	+475	+15	+30	-25
	750/65R25(L3)	-160	-120	-105	-100	+25	-60	+50
	23.5-25-20PR(L3)	-640	-480	-415	-405	-85	-60	+50
	26.5-25-20PR(L3)	± 0	± 0	± 0	± 0	± 0	± 0	± 0
	26.5-25-20PR(L4)	+480	+360	+310	+305	± 0	± 0	± 0
	26.5-25-20PR(L5)	+840	+625	+545	+535	± 0	± 0	± 0
Counter weight	+360	+920	+800	+790	-	-	+100	
Belly guard	+115	+175	+150	+150	-	-	-	
CE package	+195	+220	+200	+200	-	-	-	
CE package & Belly guard	+280	+360	+320	+320	-	-	-	

Brake system

Service brake	4-wheel wet-disc Controlled by fully hydraulic system Dual circuits
Parking brake	Spring applied oil pressure released type located on front driveline

Steering system

Type	Articulated frame steering, hydraulic power steering unit, pilot operated type
Steering valve	Kawasaki, Orbitroll and spool type
Full articulation angle	40 to each side

Loading system

Type	Front end loading, Z bar linkage system	
Hydraulic cycle time	Lifting(at full load)	6.1 sec
	Lowering(empty)	3.0 sec
	Dumping	1.3 sec
	Total cycle time	10.4 sec







Hydraulic system

Oil pump	Steering oil pump	Gear type, 227 lit/min 6.9 MPa(70 kg/cm ²) @ 2,100 rpm
	Main oil pump	Gear type, 143 lit/min, 6.9 MPa(70 kg/cm ²) @ 2,100 rpm
	Pilot oil pump	Gear type, 103 lit/min, 6.9 MPa(70 kg/cm ²) @ 2,100 rpm
Lift cylinder	type	Double acting piston
	number,bore x stroke	2 X 170 mm bore X 864 mm stroke
Tilt cylinder	type	Double acting piston
	number,bore x stroke	2 X 140 mm bore X 624 mm stroke
Steering cylinder	type	Double acting piston
	number,bore x stroke	2 X 100 mm bore X 450 mm stroke
Relief set pressure	Control valve	20.6 MPa(210 kg/cm ²)
	Steering valve	20.6 MPa(210 kg/cm ²)

Service refill

Fuel tank	370 lit
Engine lubricant(including oil pan)	37 lit
Engine cooling water	60 lit
T/M & T/C	60 lit
Axle front/rear	154 lit
Hydraulic system	155 lit
Hydraulic system(including oil tank)	260 lit

Bucket

			Standard boom					
			General purpose(Stock pile)		General purpose(Loose material)		Rock V-edge	Coal straight
			Bolt-on edges	Teeth	Bolt-on edges	Teeth	Teeth	Bolt-on edges
			GSC	GST	LSC	LST	RVT	
								
Bucket capacity	heaped	m ³	4.0	3.8	4.5	4.3	3.6	6.0
	struck	m ³	3.4	3.2	3.9	3.7	3.0	5.3
Max. dumping clearance		mm	3,130	3,005	3,045	2,920	2,895	2,790
Max. dumping reach		mm	1,180	1,260	1,260	1,340	1,370	1,450
Max. hinge pin height		mm	4,360					
Digging depth (with bucket level)		mm	65	95	65	95	95	65
Breakout force		kN	206	223	190	204	192	152
Bucket tilt-back angle		deg	50 °					
Overall length		mm	8,600	8,745	8,715	8,860	8,900	9,070
Overall height	up to cab top	mm	3,535					
	bucket full raise	mm	5,935	5,935	6,055	6,055	5,755	6,340
Overall width	outside tire	mm	2,930					
	outside bucket	mm	3,100	3,120	3,100	3,120	3,120	3,100
Tread		mm	2,230					
Wheel base		mm	3,400					
Min. turning radius (bucket carry position)	at outside bucket	mm	6,840	6,890	6,875	6,920	6,890	7,010
	at center of outside tire	mm	5,800					
Min. ground clearance		mm	515					
Full articulation angle		deg	40 °					
Operating weight		kg	22,925	22,785	23,125	22,985	23,150	23,435
Static tipping load	straight	kg	17,135	17,320	16,820	17,000	16,755	15,175
	at 37 °	kg	14,940	15,100	14,670	14,820	14,610	13,230
	full turn	kg	14,670	14,830	14,405	14,550	14,345	12,990

The weight and load figure includes 26.5 (L3) tubeless tire, ROPS cab, lubricant, coolant, full fuel tank and operator.

Bucket selection charts

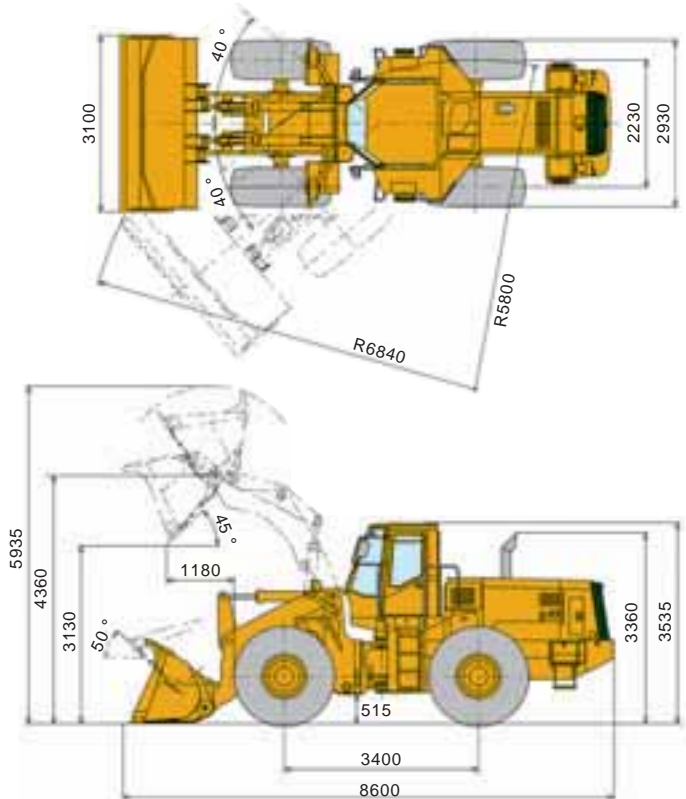
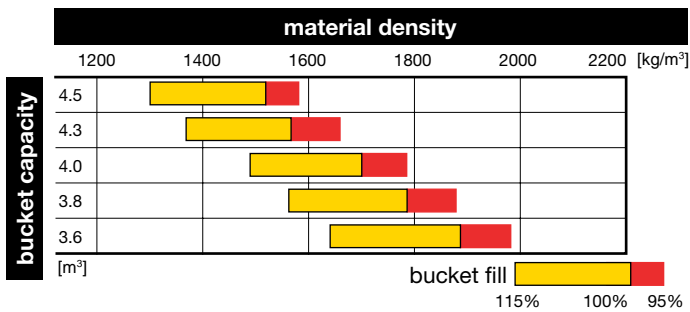

Equipped with GSC bucket, 26.5 (L3) tubeless tire and ROPS cab.

STANDARD EQUIPMENT (Standard specifications may vary. Contact your Kawasaki dealer for specifics.)

Electrical

75 ampere generator
Back up alarm
Brake and tail lights
Electric starter
Halogen headlights with high and low beams (2 front)
Halogen working lights (4 front and 4 rear)
Turn signals with four-way flasher

Gauges and indicators

Air cleaner warning lamp
Auto shift indicator lamp
Battery charge lamp
Brake pressure warning lamp
Engine coolant temperature gauge and warning lamp
Engine oil pressure warning lamp
Fuel level gauge
High beam indicator lamp
Hour meter
Neutral indicator lamp
Parking brake indicator lamp
Speedometer
Torque converter oil temperature gauge and warning lamp
Transmission control warning lamp
Transmission declutch lamp
Transmission status monitor
Working light indicator lamp

Operator environment

Adjustable operator seat with suspension
Ashtray
Cup holder
Boom/bucket control dual levers
Cigarette lighter
Machine Operation Diagnostic Module (MODM)
Electric dual horns
Floor mat
Front and rear wiper and washers
Full automatic air conditioner
Down shift button
Lockable doors with sliding windows by regulator handles (left and right)
Rearview mirrors (interior and exterior)
ROPS/FOPS cab
(left and right doors open, walk-through design)
Seat belt
Storage compartment
Sun visor
Telescopic and tilt steering wheel
Tinted safety glass (laminated glass)
Transmission declutch adjust switch

Power train

Air cleaner, double elements dry type
Cummins QSM11 diesel engine
Full hydraulic enclosed wet multi-disc brakes
Hydraulic engine radiator cooling fan
Kawasaki auto shift transmission
Kawasaki axles, torque proportioning differentials (front/rear)
Kawasaki torque converter
Low maintenance drive shafts
Tires, 26.5 (L3) tubeless

Others

Bucket leveler
Drawbar hitch with pin
Efficient loading system
Handrails
Adjustable kickout device
Ladders, left and right
Loading linkage, sealed Z-bar type dual cylinders
Secondary brake

OPTIONAL ITEMS

Additional counter weight
Additional F-R directional switch
Anti-corrosion specifications
Automatic reversible cooling fan
Cassette player with radio (AM/FM stereo)
CE package
Emergency steering
Front and rear wide fenders
High lift boom arm
Hot slag handling package

Hydraulic circuit for quick coupler pins
Hydraulic three spool valve system
K-Lever steering (stick steering control)
LED rear lamps
Limited slip differential
Loading linkage, sealed Z-bar type single cylinder
Log handling package
Mudflaps
Pre cleaner

Quick coupler
Ride control (speed sensitive automatic)
Radio-ready kit
(12V converter, antenna and wiring, stereo speakers)
Several bucket and tire options are available
Shift hold switch
Transmission belly guard
Vandalism protection kit
Waste handling package

90ZV-2

KAWASAKI HEAVY INDUSTRIES, LTD. CONSTRUCTION MACHINERY DIVISION

<http://www.khi.co.jp/kenki/english/>

TOKYO HEAD OFFICE: WORLD TRADE CENTER BLDG., 2-4-1 HAMAMATSU-CHO, MINATO-KU, TOKYO 105-6116, JAPAN.
PHONE: 81-3-3435-2901 FAX: 81-3-3435-3480

This specification sheet may contain attachments and optional equipment which are not available in your area.
Please contact your local Kawasaki dealer for those items which you require.

Materials and specifications are subject to change without notice and without obligation on the part of the manufacturer.
The specifications supplied, while believed to be completely reliable, are not to be taken as warranty for which we assume legal responsibility.